

DELTA 76

THERMAL LAMINATOR

KOMFI®

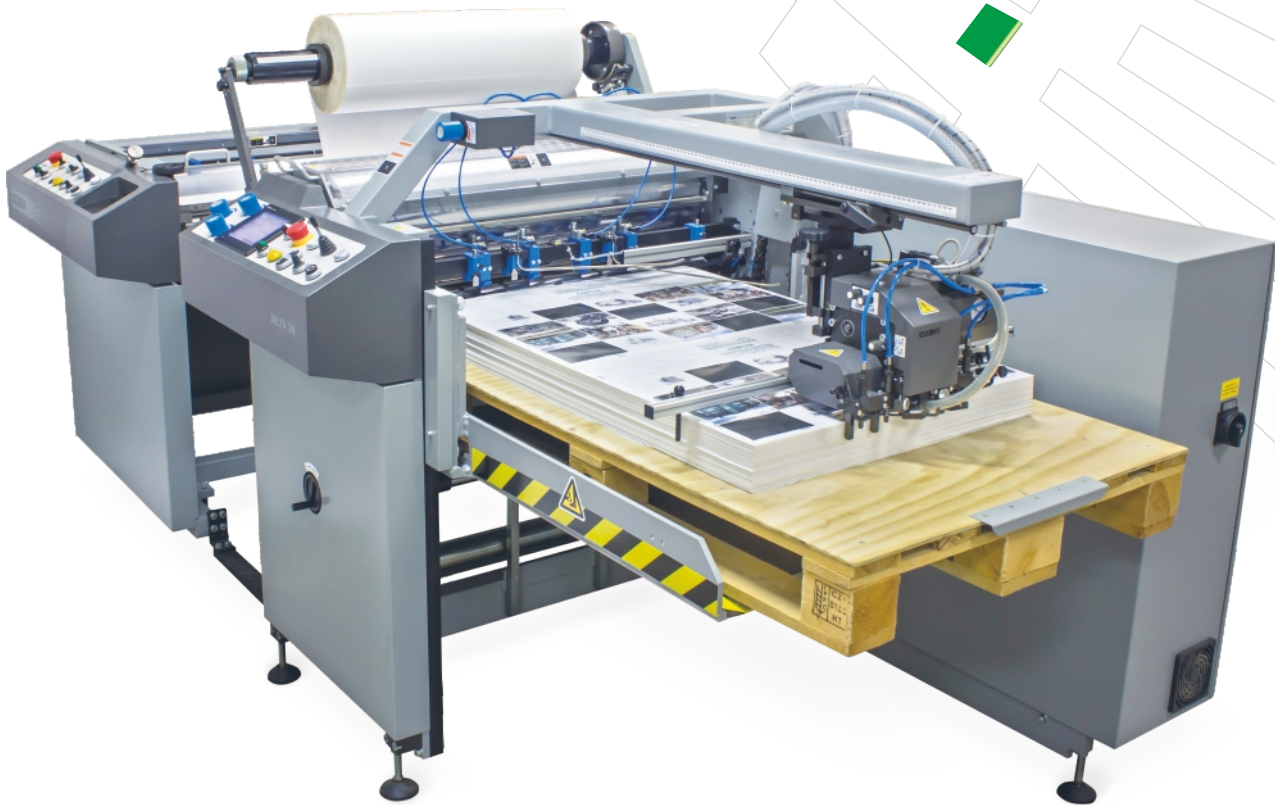

SUITABLE FOR PROCESSING
OF MEDIUM TO HIGH VOLUME OFFSET PRINTED JOBS

- Installed worldwide in 24/7 environments
- Unique software features to optimise production and minimise waste sheets
- Designed for unattended operation
- Easily accessible functional parts for simple maintenance
- Processor controlled feeding head to provide accurate sheet feeding
- Electronically controlled gate for precise and stable sheet overlap at any production speed
- Easy and fast setting of job and machine parameters through a large graphical touch screen
- Outstanding temperature stability thanks to original PID controlled segmented heating system
- Ability to process any digital and standard thermal laminating film available on the market

DESIGNED AND MANUFACTURED IN THE CZECH REPUBLIC

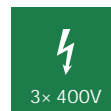

MACHINE CONFIGURATION SCHEME

B = basic O = option

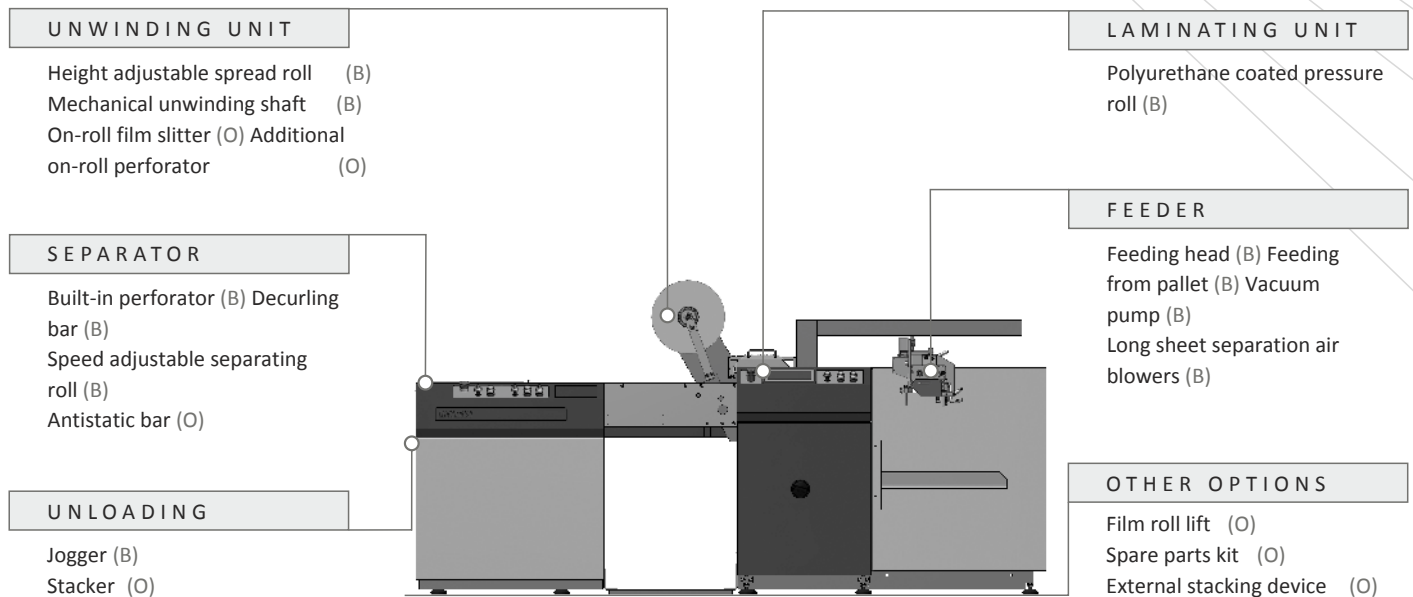

BASIC CONFIGURATION

- Komfi-design feeding head
- Feeding from pallet
- Vacuum pump
- Long sheet separation air blowers
- Automatic sheet overlap control
- Mechanical unwinding shaft with cones
- Laminating cylinder heated by 5-zone electro-resistance heater
- Polyurethane coated pressure roll
- Automatic sheet separation using built-in perforator Snapping unit pneumatically controlled
- Speed adjustable separating roll
- Jogger

OPTIONS

- Machine options in details on www.komfilaminators.com

CUSTOM-BUILT SOLUTIONS

- Possibility of individual machine modification based on specific requirements

TECHNICAL PARAMETERS

Maximum speed of lamination:	35 m/min
Maximum sheet dimensions:	76 × 112 cm (29.5 × 44")
Minimum sheet dimensions:	30 × 22 cm (11.8 × 8.6")
Paper weight:	115-600 g/m ²
Thickness of laminating film:	24-50 μm
Kind of laminating film:	OPP, PET, Nylon
Time of laminating roll warm up (25±100 °C):	5 min
Sheet overlap accuracy (at constant laminating speed):	±1 mm
Machine dimensions including delivery desk (L × W × H):	428 × 156 × 132 cm
Air supply:	6 bar
Air consumption at stable run:	50 l/min

The technical parameters may change without prior notice. Find more details about the product and its technical parameters on www.komfilaminators.com.



WEB PAGE

KOMFI spol. s r. o. | Dvo ákova 1001 | 563 01 Lanškroun | Czech Republic | info@komfi.cz | www.komfilaminators.com
Distrib tor pre SR:



GRAFITEC SLOVAKIA GROUP s.r.o. | Račianska 190 | 831 06 Bratislava | grafitec@grafitec.sk | www.grafitec.sk